

Application examples for networking, connection and load management for charging stations AMEDIO®



Table of contents

1	About this document.....	3
1.1	Target groups.....	3
2	Configure charging station	4
2.1	Connections on the ECU.....	4
2.2	Setting up a connection to the ECU.....	4
2.2.1	Via USB.....	5
2.2.2	Via Ethernet.....	5
2.2.3	Via the network.....	5
2.2.4	Setup data sheet.....	6
2.3	Structure of the web interface.....	7
2.3.1	Activate new web interface.....	7
2.3.2	Operating the web interface.....	7
2.3.3	View status information.....	8
2.4	Reset the configuration to the factory setting.....	9
3	Power supply connection diagram	10
3.1	Three-phase operation (delivery state).....	10
3.2	Three-phase operation of multiple charging stations.....	11
3.3	Single-phase operation.....	13
4	Set up network.....	17
4.1	Set up network with dynamic IP addresses (DCHP).....	18
4.1.1	ECU as DHCP server with networking via a switch.....	18
4.1.2	Router as DHCP server.....	20
4.2	Set up network with static IP addresses.....	21
4.2.1	Via the USB port of each charging station.....	22
4.2.2	Via the network.....	24
4.3	Integrating the product into an existing charging point network.....	25
5	Connection of several charging points to a backend system via a SIM card	26
5.1	Define Gateway charging point.....	27
5.2	Select OCPP communication protocol.....	29
5.3	Additional settings for local networking with statically assigned IP addresses.....	29
6	Connection of several charging points to a backend system via LAN / Ethernet (RJ45) and an external router	33
7	Operation of local and dynamic load management (DLM).....	35
7.1	Use case: Car park with two charging points.....	37
7.2	Use case: Car park with several charging points.....	39
7.3	Use case: Car park with several charging stations and common power connection.....	40
7.4	Use case: Consideration of dynamic measured values of an external energy meter (Standalone application with one charging point and Master-Satellite application with several charging stations and common power connection).....	42
7.4.1	Option 1: Energy meter measures external consumers only.....	43
7.4.2	Option 2: Energy meter measures external consumers and charging stations (total consumption)..	47
7.5	Use case: Activate the interface (Modbus TCP server) for energy management systems (EMS).....	51

7.6	Use case: Downgrade when using the energy meter Siemens 7KM2200 (TCP)	52
7.7	Static load profile for 24 hours.....	53
8	Unbalanced load prevention.....	55
9	Downgrade input.....	57
10	Glossary	60

1 About this document

This document is a supplement to the operating and installation manual of the respective charging station. It contains useful information and application examples for networking, connection and load management. The content of this document refers to the ECU firmware 5.12.6.

This document applies to the following product variants:

- AMEDIO® Professional(+) 22 (PnC)
- AMEDIO® Professional(+)* 22 (PnC) – calibration law-compliant –



Comply with the information in all additional documents and especially the operating and installation manuals for your product.

Copyright ©2021 Mennekes Elektrotechnik GmbH & Co. KG

1.1 Target groups

This document provides information for the qualified electrician only.

Qualified electricians

A qualified electrician is a person who, based on his or her professional education, knowledge and experience as well as knowledge of relevant provisions, can assess the work assigned to him or her and identify possible hazards.

2 Configure charging station

2.1 Connections on the ECU



Both charging points in the product are pre-configured as a master/slave connection (for OCPP). Both charging points can be configured via the ECU on the right-hand side (slave ECU; AF2).

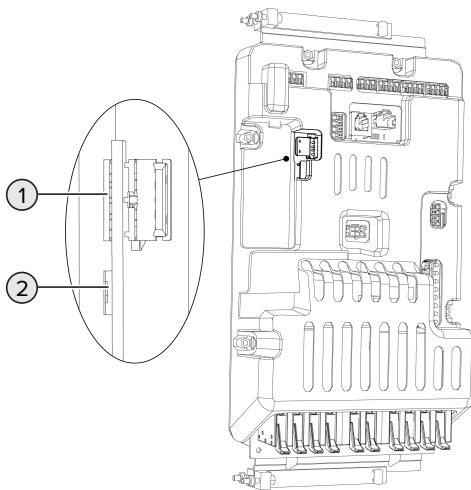

Fig. 1: Connections on the ECU

Item	Usage	Connection / slot
1	SIM card ▶ Use the slot on the left-hand ECU (AF1).	Micro-SIM
2	Configuring the product ▶ Use the connection on the right-hand ECU (AF2).	Micro-USB

2.2 Setting up a connection to the ECU

If the product is connected to a terminal device (e.g. PC, laptop), the product can be configured and status information can be retrieved. Configuration takes place via the web interface in a current web browser. The web interface is password-protected.

The following options are available for setting up a connection to the ECU:

2.2.1 Via USB

- ▶ Connect terminal device (e.g. PC, laptop) and ECU with a USB cable.

📄 “2.1 Connections on the ECU” [▶ 4]



If the driver is not automatically installed under the Windows operating system:

- ▶ Navigate to “Control Panel” > “Device Manager” > “Other devices”.
 - ▶ Right-click on “RNDIS/Ethernet Gadget” > “Update Driver Software” > “Search for driver software on the computer” > “Select from a list of device drivers on the computer” > “Network Adapter” > “Microsoft Corporation” > “NDIS-compatible remote device”.
- ⇒ The driver is installed.

- ▶ Open web browser.

The web interface can be reached via <http://192.168.123.123>.

- ▶ Enter the user name (operator) and password of the master charging point.

📄 “2.2.4 Setup data sheet” [▶ 6]

2.2.2 Via Ethernet

- ▶ Connect terminal device (e.g. PC, laptop) and ECU with an Ethernet cable. To do this, use the Ethernet port on the Ethernet surge protection.

- ▶ Configure the network of the terminal device as follows:

- IPv4 address: 192.168.124.21
- Subnet mask: 255.255.255.0
- Standard gateway: 192.168.124.1

- ▶ Open web browser.

The web interface can be reached via <http://192.168.124.123>.

- ▶ Enter the user name (operator) and password of the master charging point.

📄 “2.2.4 Setup data sheet” [▶ 6]

2.2.3 Via the network

Once the product is integrated into the network via Ethernet, the web interface can also be reached via a terminal device that is located in the same network.

Requirement(s):

- ✓ The product must be integrated into a network.
- ✓ A terminal device (e.g. PC, laptop) must also be integrated in the network via the router / switch.
- ✓ The IP address of the product must be known.



If the IP address of the product is not known (e. g. due to dynamic IP address configuration by a DHCP server), the IP address can either be set via a network scan (installed as a free tool on the terminal device) or via the web interface of the router / switch.

- ▶ Open web browser on terminal device.
The web interface can be reached via `http://IP address`.
Example:
 - IP address: 192.168.0.70
 - The web interface can be reached via: `http://192.168.0.70`
 - ▶ Enter the user name (operator) and password of the master charging point.
-  “2.2.4 Setup data sheet” [▶ 6]



By entering the relevant IP address in the web browser, each product in the network can be configured via the terminal device.



The serial number of the respective product is displayed at the top right of the login page for better correlation with the setup data sheet.

2.2.4 Setup data sheet

The setup data sheet is included in the scope of delivery of the charging station.

Commissioning Data Sheet
Einrichtungsdatenblatt



Serial Number:
140802412.00015

Credentials

User Name Master:	operator
Password Master:	6eBb1vDc
Password Slave:	TqJkkLZe

Device Data

Application Version Master:	4.52-5412-d6a2288f6
Application Version Slave:	4.52-5412-d6a2288f6
Controller Serial Number Master:	1903523062/B94060045
Controller Serial Number Slave:	1903527652/B94060046
Meter Serial Number Master:	093609
Meter Serial Number Slave:	093633

Fig. 2: Setup data sheet for AMEDIO® (example)

2.3 Structure of the web interface

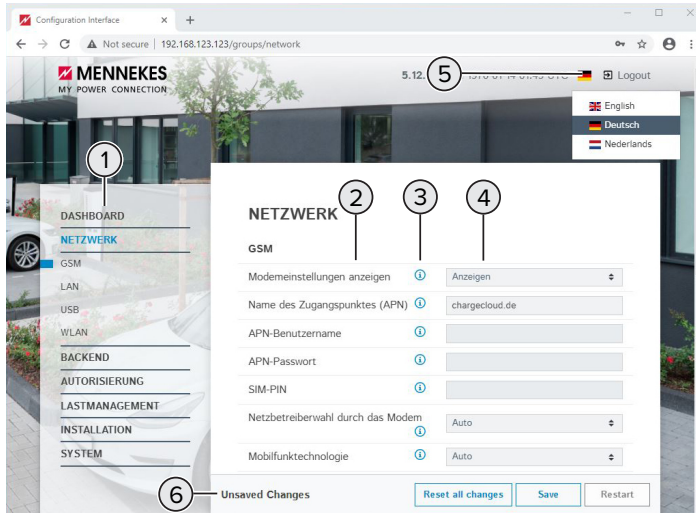

Fig. 3: Structure of the web interface for firmware version 5.12.3 (example)

- 1 Menu
- 2 Parameter
- 3 Note / information *
- 4 Setting / status
- 5 Language selection button
- 6 Button to reset and save the changed settings and restart the product



* The notes / information (3) contain a great deal of important information that provides tips on the respective parameter and for configuration purposes.

2.3.1 Activate new web interface

As of firmware version 5.12.3, the display of the web interface has been adapted. When updating the firmware from the old web interface (firmware version lower than 5.12.3) to the new web interface (firmware version 5.12.3 or higher), the new web interface must be activated manually.

- ▶ Navigate to the “Operator” menu.
- ▶ Set the “Web Interface” parameter to “2.0”.
- ▶ Click the “Save & Restart” button to activate the new web interface.

2.3.2 Operating the web interface

- ▶ Configure the product taking into account the local conditions and customer requirements.



Changed settings that have not yet been saved are highlighted in blue. The Save button is displayed. Before the menu can be exited, the changed settings must either be saved (“Save”) or reset (“Reset all changes”).

After the product has been fully configured, a restart is required.

► Click the “Restart” button to restart the product.

2.3.3 View status information

The screenshot shows a 'Dashboard' menu on the left with options: DASHBOARD, NETWORK, BACKEND, AUTHORIZATION, LOAD MANAGEMENT, INSTALLATION, and SYSTEM. The main content area displays the following information:

System Status

Parameter	Connector 1
Type2 State	(A) Vehicle not connected PR: NO CABLE Plug not locked
Signaled Current	0 A
Contactor Cycles Type2	0
Type 2 Plug Cycles	0
Error(s)	External meter not communicating
RCMB state	RMS: OK, DC: OK, RCMB Device Status(IEC 62752): OK Last transaction maximum RMS: 30.0 mA, DC: 6.0 mA Values RMS: 0.0 mA, DC: 0.1 mA

Interfaces

Eichrecht State	System without Eichrecht
-----------------	--------------------------

Energy Manager

Energy Manager | OCPP Meter | Second Meter

Name	Value	Description
Energy Manager Main State	0 A	Energy manager overall state and current

Fig. 4: “Dashboard” menu

Status information about the product is displayed in the “Dashboard” menu, e.g.

- Current state
 - Fault messages
 - Charging processes
 - IP address (parameter “Interfaces”)
 - ...
- Configuration settings made
 - Load management
 - Connection of an external energy meter
 - ...

2.4 Reset the configuration to the factory setting

The configurations that affect the master charging point and the configurations that affect the slave charging point must be reset separately.

Master charging point

- ▶ Enter the ending "81/legacy/operator/operator" in the address line of the web browser (e.g. 192.168.123.123.81/legacy/operator/operator).
- ▶ Enter the user name (operator) and password of the master charging point.
-  "2.2.4 Setup data sheet" [▶ 6]
- ▶ Click the button "Operator Default & Restart" to restore the factory settings and restart the product.

Slave charging point

- ▶ Enter the ending "82/legacy/operator/operator" in the address line of the web browser (e.g. 192.168.123.123.82/legacy/operator/operator).
- ▶ Enter the user name (operator) and password of the slave charging point.
-  "2.2.4 Setup data sheet" [▶ 6]
- ▶ Click the button "Operator Default & Restart" to restore the factory settings and restart the product.

3 Power supply connection diagram

3.1 Three-phase operation (delivery state)

To ensure that the network load is distributed as evenly as possible, the connection of the right-hand charging socket is phase-shifted by 120° (see illustration). This favours the network load for single-phase charging of multiple vehicles, as charging is distributed over two different phases.

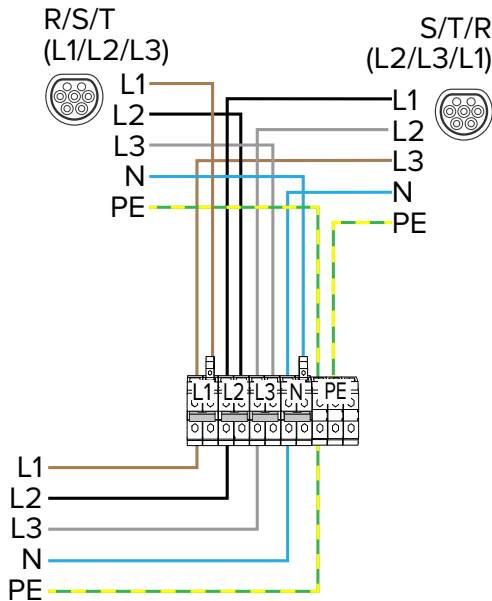

Fig. 5: Supply network connection diagram for three-phase operation

Settings in the web Interface

In the delivery state, the following settings are made in the menu "Installation" > "General Installation" of the web interface:

Three-phase operation / left-hand charging point	
Parameter	Web interface setting
Phases connected to the ChargePoint	Three-phase system
Phase rotation of the ChargePoint	RST (L1/L2/L3, Standard Reference Phasing)

Three-phase operation / right-hand charging point	
Parameter	Web interface setting
Phases connected to the ChargePoint (Connector 2)	Three-phase system
Phase rotation of the ChargePoint (Connector 2)	STR (L2/L3/L1, Standard 120 degree rotaion)

3.2 Three-phase operation of multiple charging stations

To ensure that the network load is distributed as evenly as possible, we recommend connecting the supply lines to the terminals of the AMEDIO® with phase reversal (see illustration).

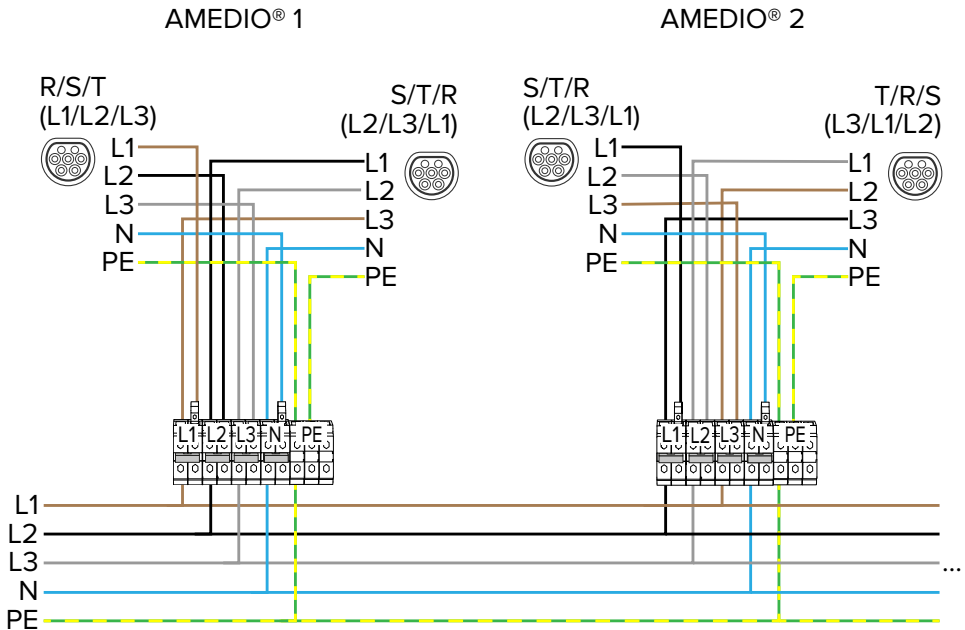

Fig. 6: Supply network connection diagram for multiple charging stations in three-phase operation

This illustration is incomplete. More AMEDIO® devices can be connected to the same power supply using the phase reversal principle referred to above. From a fourth connected AMEDIO®, the recommended phase position and the necessary settings in the web interface are repeated.

Connected AMEDIO®	Charging point	Input terminal		
		L1	L2	L3
AMEDIO® 1	LP 1 / left-hand ECU	L1	L2	L3
	LP 2 / right-hand ECU	L2	L3	L1

Connected AMEDIO®	Charging point	Input terminal		
		L1	L2	L3
AMEDIO® 2	LP 1 / left-hand ECU	L2	L3	L1
	LP 2 / right-hand ECU	L3	L1	L2
AMEDIO® 3	LP 1 / left-hand ECU	L3	L1	L2
	LP 2 / right-hand ECU	L1	L2	L3
AMEDIO® 4 (cf. AMEDIO® 1)	LP 1 / left-hand ECU	L1	L2	L3
	LP 2 / right-hand ECU	L2	L3	L1
...

Settings in the web Interface

To allow the correct assignment between each charging point and the applied phase position, the correct phase position for each charging point must be set in the web interface. As a result, an overload can be prevented when operating load management, for example.

- ▶ In the web interface of each charging station, navigate to the menu “Installation” > “General Installation”.
- ▶ Set the following parameters in the web interface of each networked charging station:

AMEDIO® 1	
Parameter	Web interface setting
Phases connected to the ChargePoint	Three-phase system
Phases connected to the ChargePoint (Connector 2)	Three-phase system
Phase rotation of the ChargePoint	RST (L1/L2/L3, Standard Reference Phasing)
Phase rotation of the ChargePoint (Connector 2)	STR (L2/L3/L1, Standard 120 degree rotaion)

AMEDIO® 2	
Parameter	Web interface setting
Phases connected to the ChargePoint	Three-phase system
Phases connected to the ChargePoint (Connector 2)	Three-phase system
Phase rotation of the ChargePoint	STR (L2/L3/L1, Standard 120 degree rotaion)
Phase rotation of the ChargePoint (Connector 2)	TRS (L3/L1/L2, Standard 240 degree rotation)

AMEDIO® 3	
Parameter	Web interface setting
Phases connected to the ChargePoint	Three-phase system
Phases connected to the ChargePoint (Connector 2)	Three-phase system

AMEDIO® 3	
Parameter	Web interface setting
Phase rotation of the ChargePoint	TRS (L3/L1/L2, Standard 240 degree rotation)
Phase rotation of the ChargePoint (Connector 2)	RST (L1/L2/L3, Standard Reference Phasing)

- ▶ Click the “Save” button to save the setting(s).

3.3 Single-phase operation

Phase sequence relay

To operate the product in single-phase, the potentiometer on both sequence relays must be changed over.

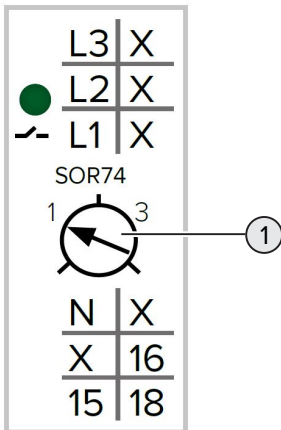

- ▶ Adjust potentiometer (1) to position 1 using a slotted screwdriver.

Setting	Description
1	Single-phase operation
3	Three-phase operation

Power supply

The product can be connected in a TN / TT network.

The product can only be connected in an IT network under the following conditions:

- ✓ Connection to a 230 / 400 V IT network is not permitted.
- ✓ Connection to an IT network with 230 V external line voltage over a residual current circuit breaker is permissible, provided that the maximum contact voltage does not exceed 50 V AC when the first error occurs.

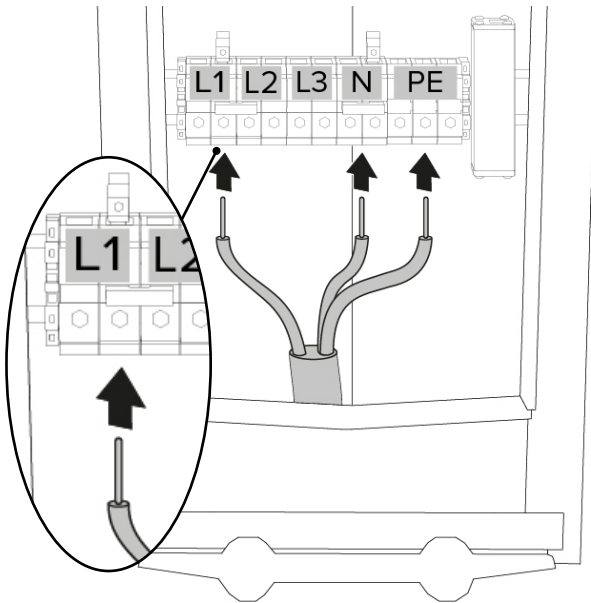

Fig. 7: Power supply connection (example: single-phase operation)

- ▶ Strip the supply line.
- ▶ Strip conductors 12 to 18 mm.



Multiple products can be connected in series (loop through supply cable).



When routing the supply line, comply with the permissible bending radius.

- ▶ Connect the wires of the supply line to the terminals L1, N and PE as per the terminal labelling.
 - ▶ Comply with the connection data for the terminals.
-  Operating and installation manual: "4 Technical data"



The terminal on the **right-hand side** of the two L1 terminals must be used for single-phase operation.

Reconnect the jumpers at the terminals of the power supply

For single-phase operation of the product, the jumpers at the terminals of the power supply must be reconnected .

ATTENTION

Material damage due to incorrectly connected jumpers

An electrical short-circuit will occur if the jumpers are configured for single-phase operation and the product is connected for three-phase operation. This can cause material damage in the upstream electrical installation.

- ▶ Set the jumpers in accordance with the product connection.
- ▶ Use a slotted screwdriver to remove the jumpers (except for the jumper at the N terminals).
- ▶ Connect a jumper between terminals L1 and L2.
- ▶ Check that the jumper is tightly fitted and can only be removed by using a tool.

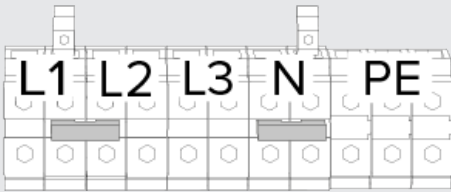
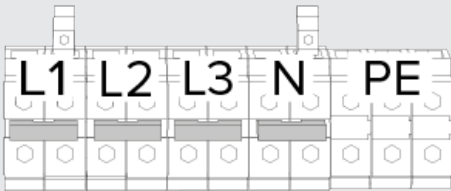

Only two jumpers are required for single-phase operation.

Operation	Position of jumpers
single phase	
three phase	

Web interface

- ▶ In the web interface, navigate to the menu “Installation” > “General Installation”.
- ▶ Set the following parameters in the web interface:

Single-phase operation / left-hand charging point	
Parameter	Web interface setting
Phases connected to the ChargePoint	Single-phase system
Phase rotation of the ChargePoint	RST (L1/L2/L3, Standard Reference Phasing)

Single-phase operation / right-hand charging point	
Parameter	Web interface setting
Phases connected to the ChargePoint (Connector 2)	Single-phase system
Phase rotation of the ChargePoint (Connector 2)	RST (L1/L2/L3, Standard Reference Phasing)

Three-phase operation / left-hand charging point	
Parameter	Web interface setting
Phases connected to the ChargePoint	Three-phase system
Phase rotation of the ChargePoint	RST (L1/L2/L3, Standard Reference Phasing)

Three-phase operation / right-hand charging point	
Parameter	Web interface setting
Phases connected to the ChargePoint (Connector 2)	Three-phase system
Phase rotation of the ChargePoint (Connector 2)	STR (L2/L3/L1, Standard 120 degree rotaion)

4 Set up network

This product can be networked with all charging stations with ECU (AMEDIO®, AMTRON® Professional, AMTRON® Charge Control).



The ECUs with different firmware version are essentially compatible with one another (for connecting several charging points to a backend system or for load management). The firmware version listed below is an exception:

- Version 4.52 is not compatible with higher firmware versions. A firmware update is required before networking.

The products must be connected to a central router or switch via an Ethernet cable (max. length 100 m) in order to connect several products to form a network. The wiring must be carried out in star topology.



Fig. 8: Set up network (example)

Local networking can be used for the following function(s):

- Connection of several charging points to a backend system via a SIM card (wireless communication).
- Connection of several charging points to a backend system via LAN / Ethernet (RJ45) and an external router
- Operation of local and dynamic load management (DLM)

4.1 Set up network with dynamic IP addresses (DHCP)

4.1.1 ECU as DHCP server with networking via a switch



The easiest way to set up a network is to use the ECU as a DHCP server and network the charging stations via a switch.



To connect to the backend system via a SIM card (wireless communication) with dynamic IP address configuration, it is necessary to use an ECU as a DHCP server.

📄 “5 Connection of several charging points to a backend system via a SIM card” [26]

If the charging points are connected via a switch, the charging points can be configured for network communication. The dynamic IP address assignment for the ECUs in the network is made by any desired ECU in the same network, which is configured as a DHCP server. One ECU in the network must therefore be configured as a DHCP server and all other ECUs as a DHCP client:

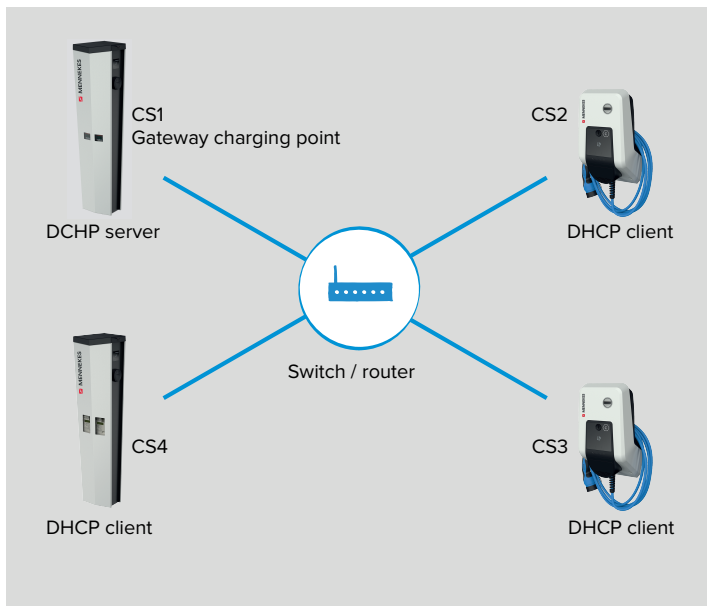

Fig. 9: CS1 as DHCP server

The ECU that is configured as a DHCP server must be the same ECU that will subsequently be configured as the Gateway for communication with the backend system.

📄 “5 Connection of several charging points to a backend system via a SIM card” [26]



When configuring the DHCP server, no DHCP client must be present in the network. These must first be deactivated or disconnected from the switch.

- ▶ Deactivate the DHCP clients or disconnect them from the switch.

Settings in the web interface of the DHCP server

- ▶ In the web interface of the DHCP server, navigate to the menu “Network” > “LAN”.

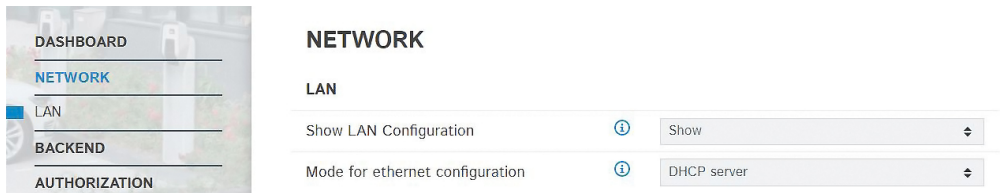

Fig. 10: Web interface of the DHCP server for configuring dynamic IP addresses

- ▶ Set the following parameters in the web interface of the DHCP server:

Parameter	Web interface setting - CS1 / DHCP server
Show LAN Configuration	▶ Select “Show”.
Mode for ethernet configuration	▶ Select “DHCP server”.

- ▶ Click the “Save” button to save the setting(s).
- ▶ Reactivate the DHCP clients or reconnect them to the switch (only if the configuration takes place via the network).

Required settings in the web interface				
Parameter	CS1 / DHCP server	CS2 / DHCP client	CS3 / DHCP client	...
Mode for ethernet configuration	DHCP server	Auto (DHCP client)	Auto (DHCP client)	Auto (DHCP client)



The “Mode for ethernet configuration” parameter is set to “Auto (DHCP client)” on delivery.

The charging stations are now networked. By entering the relevant IP address in the web browser, each ECU in the network can be configured via the terminal device.



IP address configuration via the DHCP server takes place step by step (incremental). It begins with 172.16.23.100 and ends with 172.16.23.254. Alternatively, the IP addresses can be determined via a network scan (install as a free tool on the terminal device).

4.1.2 Router as DHCP server



To connect to the backend system via LAN / Ethernet (RJ45) and an external router, it is necessary to use the router with the Internet connection as a DHCP server.

📄 “6 Connection of several charging points to a backend system via LAN / Ethernet (RJ45) and an external router” [▶ 33]



Alternatively, the IP address configuration can also take place statically.

📄 “4.2 Set up network with static IP addresses” [▶ 21]

If the charging points are connected via a router, the charging points can be configured for network communication. The dynamic IP address assignment for the ECUs in the network is made by any router in the same network, which is configured as a DHCP server. All ECUs are configured as DHCP clients.

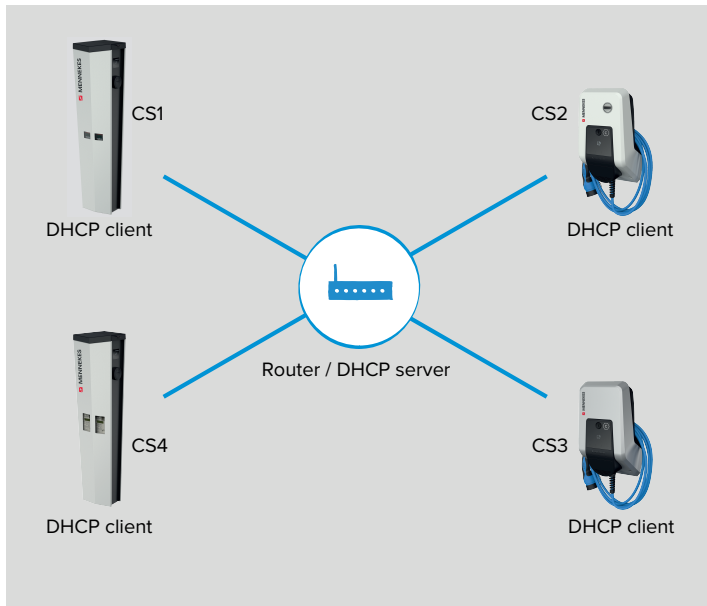

Fig. 11: Router as DHCP server

Settings in the web interface of each networked charging station

▶ In the web interface of each networked charging station, navigate to the menu “Network” > “LAN”.

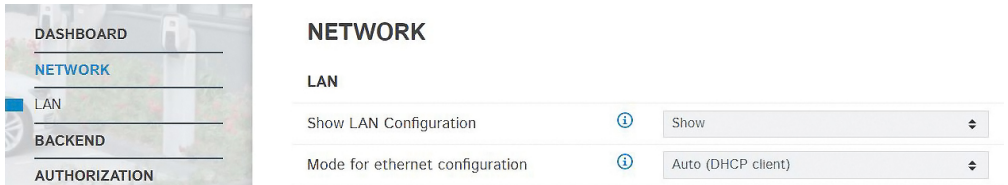

Fig. 12: Web interface of every networked charging station for configuring dynamic IP addresses

Required settings in the web interface				
Parameter	CS1 / DHCP client	CS2 / DHCP client	CS3 / DHCP client	...
Mode for ethernet configuration	Auto (DHCP client)	Auto (DHCP client)	Auto (DHCP client)	Auto (DHCP client)



The “Mode for ethernet configuration” parameter is set to “Auto (DHCP client)” on delivery.

The charging stations are now networked. By entering the relevant IP address in the web browser, each ECU in the network can be configured via the terminal device.



If the IP address of the product is not known (e. g. due to dynamic IP address configuration by a DHCP server), the IP address can either be set via a network scan (installed as a free tool on the terminal device) or via the web interface of the router / switch.

4.2 Set up network with static IP addresses

As an alternative to the dynamically assigned IP addresses, the ECUs can also be assigned static IP addresses.



Fig. 13: Static IP addresses

IP addresses can be configured in one of two ways:

- Via the USB port of each charging station
To do this, it is necessary to open each charging station and connect a USB cable to each charging station.
- 📄 “4.2.1 Via the USB port of each charging station” [▶ 22]
- Via the network
All charging stations in the network can be configured via the terminal device. The charging stations do not have to be opened in this case.
- 📄 “4.2.2 Via the network” [▶ 24]

4.2.1 Via the USB port of each charging station

- ▶ In the web interface of each networked charging station, navigate to the menu “Network” > “LAN”.

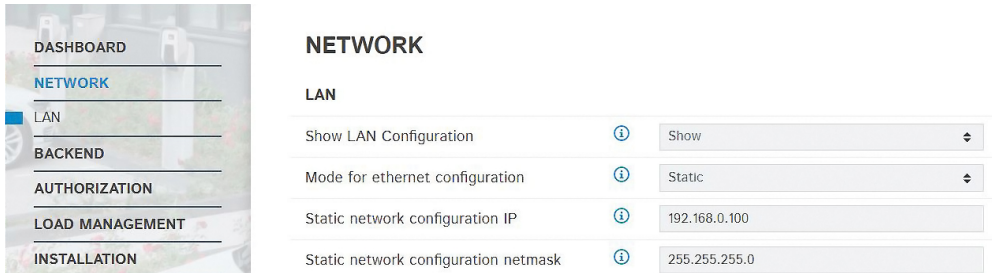

Fig. 14: Web interface of all networked charging points for configuring static IP addresses

► Set the following parameters in the web interface of each networked charging station:

Parameter	Web interface setting
Show LAN Configuration	► Select “Show”.
Mode for ethernet configuration	► Select “Static”.
Static network configuration IP	► Enter static IP address.
Static network configuration netmask	► Enter network screen.

► Select the static IP address in accordance with the switch. Requirements:

- ✓ The IP addresses of the ECUs should be numbered consecutively.
- ✓ An IP address must not be configured twice within a network.

i The address ranges below must not be used as a static IP address:

- 192.168.123.xxx
- 192.168.124.xxx
- 192.168.125.xxx

► Click the “Save” button to save the setting(s).

The charging stations are now networked. By entering the relevant IP address in the web browser, each ECU in the network can be configured via the terminal device.

Although there are two charging points, the product is always visible in the network with a single IP address. This is achieved by running the two charging points on different ports. The master charging point always runs on port 81 and the slave charging point on port 82.

Example:

- Master charging point: 192.168.0.70:81
- Slave charging point: 192.168.0.70:82

4.2.2 Via the network



In the delivered condition, all charging stations have the same static IP address. The static IP address must therefore be set for each charging station individually and in sequence. Only the charging station that is currently being configured and the charging stations that have already been configured may be switched on or integrated in the network.

- ▶ Deactivate all charging stations or disconnect them from the Ethernet switch.
- ▶ Reactivate the first charging station or reconnect it to the Ethernet switch.
- ▶ In the web interface, navigate to the menu “Network” > “LAN”.

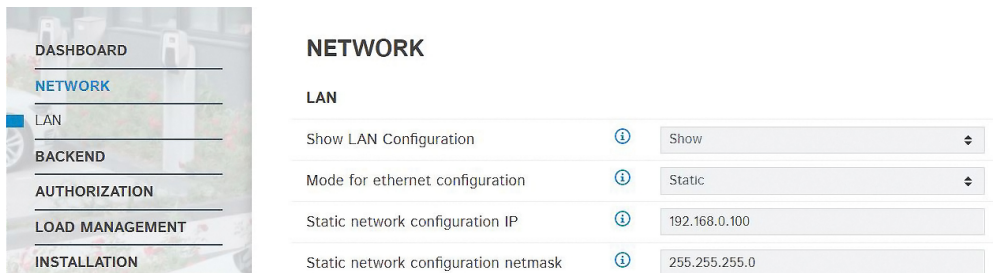

Fig. 15: Web interface for configuring static IP addresses

- ▶ Set the following parameters in the web interface:

Parameter	Web interface setting
Show LAN Configuration	▶ Select “Show”.
Mode for ethernet configuration	▶ Select “Static”.
Static network configuration IP	▶ Enter static IP address.
Static network configuration netmask	▶ Enter network screen.

- ▶ Select the static IP address in accordance with the switch. Requirements:
 - ✓ The IP addresses of the ECUs should be numbered consecutively.
 - ✓ An IP address must not be configured twice within a network.



The address ranges below must not be used as a static IP address:

- 192.168.123.xxx
- 192.168.124.xxx
- 192.168.125.xxx



If the networked charging stations are connected to a backend system via a SIM card and the IP address of the Gateway charging point is already known, the IP address can also be entered directly in the parameter “Static network configuration gateway”.

 “5.3 Additional settings for local networking with statically assigned IP addresses” [▶ 29]

- ▶ Click the “Save” button to save the setting(s).

- ▶ Activate the second charging station or connect it to the Ethernet switch and make the above-listed settings.
- ▶ ...

The charging stations are now networked. By entering the relevant IP address in the web browser, each ECU in the network can be configured via the terminal device.

Although there are two charging points, the product is always visible in the network with a single IP address. This is achieved by running the two charging points on different ports. The master charging point always runs on port 81 and the slave charging point on port 82.

Example:

- Master charging point: 192.168.0.70:81
- Slave charging point: 192.168.0.70:82

4.3 Integrating the product into an existing charging point network

To integrate the product into an existing charging point network, observe the following sequence:

1. Install and network the product.
2. Integrate the product into the charging point network via the web interface.
3. Update the firmware of all networked products.



The ECUs with different firmware version are essentially compatible with one another (for connecting several charging points to a backend system or for load management). The firmware version listed below is an exception:

- Version 4.52 is not compatible with higher firmware versions. A firmware update is required before networking.

4. Configure the product in the backend system (if necessary).
5. Perform a function test or start the charging process.

5 Connection of several charging points to a backend system via a SIM card

If multiple charging points are to be connected to a backend system via a SIM card, one charging point in the network must be configured as a Gateway. The Gateway charging point acts as an interface between the locally networked charging points on one side and the backend system on the other.



Fig. 16: CS1 as Gateway charging point



The connection to a backend system of charging stations with an ECU differs from the connection to a backend system of charging stations with an ACU. The main difference is that, for charging stations with an ECU, each master charging point can communicate with the backend system via dedicated OCPP. The backend URL must be registered in the web interface of each master ECU.

The gateway charging point with the integrated wireless communication modem acts exclusively as a router for the remaining charging points in the network.

Requirements for the network:

- ✓ The charging stations must be on the same network.
- 📄 “4 Set up network” [▶ 17]
- ✓ The IP address configuration can take place statically or dynamically. In the case of dynamic IP address configuration, the ECU must be used as a DHCP server.
- 📄 “4.2 Set up network with static IP addresses” [▶ 21]

📄 “4.1.1 ECU as DHCP server with networking via a switch” [▶ 18]

Requirement for the Gateway charging point:

- ✓ Each charging point with an integrated wireless communication modem can be configured as a Gateway (all product variants with a “+” in the name have an integrated wireless communication modem).
 - ✓ The Gateway charging point must have a micro SIM card for wireless communication.
 - ✓ When connecting to a network in which the ECU functions as a DHCP server: The charging point that is configured as a DHCP server must also be the Gateway charging point.
- 📄 “4.1.1 ECU as DHCP server with networking via a switch” [▶ 18]
- ✓ A master charging point must be configured as a Gateway, as only the master charging point contains a wireless communication modem.

Further requirements:

- ✓ The network must have only one Gateway charging point.
- ✓ For the Gateway functionality, communication with the backend system must be via OCPP 1.6j.
- ✓ The maximum number of charging points that are connected to a backend system via wireless communication must be selected depending on the network quality at the location and the available data volume. MENNEKES recommends connecting a maximum of 50 charging points to a backend system via a SIM card.

5.1 Define Gateway charging point

The Gateway charging point is defined by setting the charging point with the integrated SIM card to “On” for the parameter “WAN-Router”.

Settings in the web interface of the Gateway charging point

- ▶ In the web interface of the Gateway charging point, navigate to the menu “Backend” > “Connection”.
- ▶ Set the following parameters in the web interface of the Gateway charging point:

Parameter	Web interface setting
Connection Type	▶ Select “GSM”.

- ▶ In the web interface of the Gateway charging point, navigate to the menu “Network” > “GSM”.

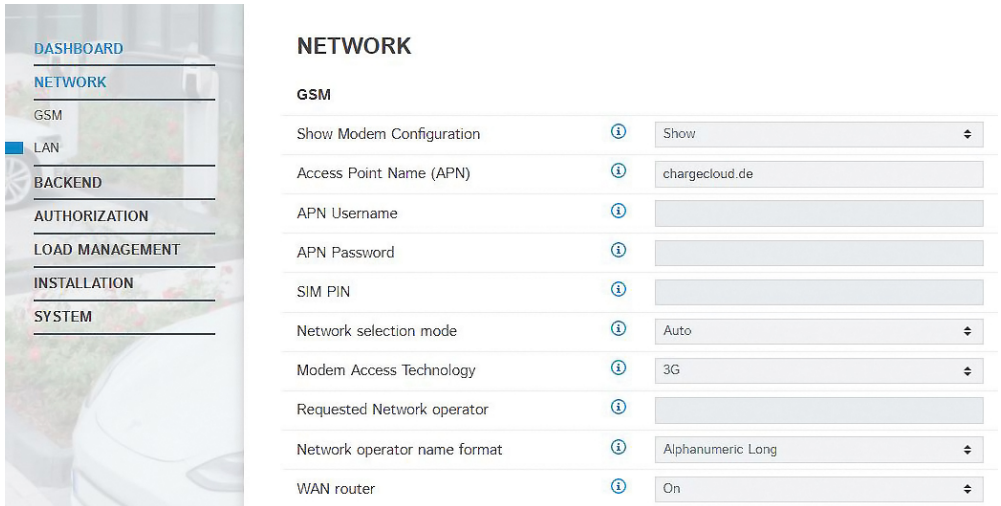

Fig. 17: Web interface of the Gateway charging point for configuring the Gateway charging point

- ▶ Set the following parameters in the web interface of the Gateway charging point:

Parameter	Web interface setting
Show Modem Configuration	▶ Select “Show”.
WAN-Router	▶ Select “On”.

Settings in the web interface of the remaining networked charging stations

- ▶ In the web interface of the remaining networked charging stations, navigate to the menu “Backend” > “Connection”.
- ▶ Set the following parameters in the web interface of the remaining networked charging stations:

Parameter	Web interface setting
Connection Type	▶ Select “Ethernet”.

- ▶ Click the “Save” button to save the setting(s).

The following settings are only required for charging stations with a wireless communication modem (all product variants with a “+” in the name have an integrated wireless communication modem). Charging stations without a wireless communication modem do not have the “GSM” menu.

- ▶ In the web interface of the remaining networked charging stations with a wireless communication modem, navigate to the menu “Network” > “GSM”.
- ▶ Set the following parameters in the web interface of the remaining networked charging stations with a wireless communication modem:

Parameter	Web interface setting
Show Modem Configuration	▶ Select “Show”.
WAN-Router	▶ Select “Off”.

▶ Click the “Save” button to save the setting(s).

5.2 Select OCPP communication protocol

▶ In the web interface of each networked charging station, navigate to the menu “Backend” > “OCPP”.

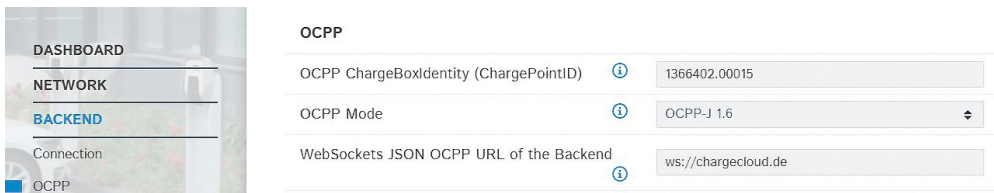

Fig. 18: Web interface of each networked charging station for configuring the OCPP communication protocol

▶ Set the following parameters in the web interface of each networked charging station:

Parameter	Web interface settings			
	CS1 / Gateway charging point	CS2	CS3	...
OCPP Mode	▶ Select “OCPP-J 1.6”.			
WebSockets JSON OCPP URL of the Backend	▶ Enter the WS / WSS-URL of the OCPP backend system.			

▶ Click the “Save” button to save the setting(s).

5.3 Additional settings for local networking with statically assigned IP addresses

The following configurations only need to be implemented if the IP addresses were assigned manually (statically).

 “4.2 Set up network with static IP addresses” [▶ 21]

If the IP addresses of all charging points in the network were assigned manually (statically), in addition to the manually entered IP address of the charging point, the IP address of the Gateway charging point in each charging point (except for the actual Gateway charging point) must also be specified.

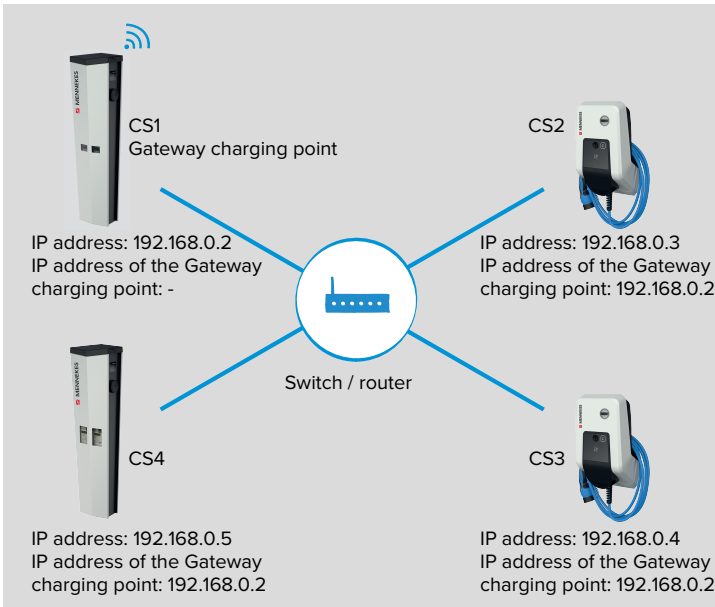

Fig. 19: CS1 as Gateway charging point

Settings in the web interface of the Gateway charging point

- In the web interfaces of the Gateway charging point, navigate to the menu “Network” > “LAN”.

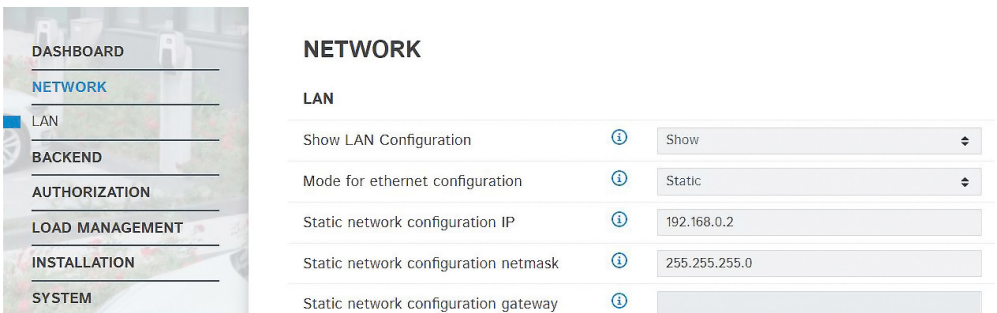

Fig. 20: Web interface of the Gateway charging point for configuring the static IP addresses

- Set the following parameters in the web interface of the Gateway charging point:

Parameter	Web interface setting
Show LAN Configuration	► Select “Show”.
Mode for ethernet configuration	► Select “Static”.

Parameter	Web interface setting
Static network configuration IP	▶ Enter static IP address.
Static network configuration netmask	▶ Enter network screen.
Static network configuration gateway	▶ Leave parameter empty.



The parameter “Static network configuration gateway” must remain empty for the Gateway charging point.

Settings in the web interface of each networked charging station

- ▶ In the web interfaces of each networked charging station, navigate to the menu “Network” > “LAN”.

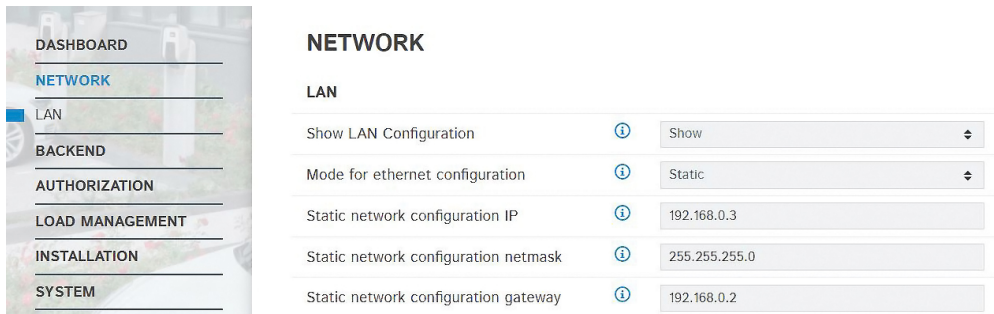

Fig. 21: Web interface of every networked charging station for configuring static IP addresses

- ▶ Set the following parameters in the web interface of each networked charging station:

Parameter	Web interface setting
Show LAN Configuration	▶ Select “Show”.
Mode for ethernet configuration	▶ Select “Static”.
Static network configuration IP	▶ Enter static IP address.
Static network configuration netmask	▶ Enter network screen.
Static network configuration gateway	▶ Enter Gateway (IP address of Gateway charging point).



In the parameter “Static network configuration gateway”, the IP address of the Gateway charging point (parameter “Static network configuration IP”) must be entered for each additional networked charging station.

Example

Parameter	Web interface settings			
	CS1 / Gate- way charging point	CS2	CS3	...
Mode for ethernet configuration	Static	Static	Static	Static
Static network configuration IP	192.168.0.2	192.168.0.3	192.168.0.4	192.168.0....
Static network configuration netmask	255.255.255. 0	255.255.255. 0	255.255.255. 0	255.255.255. 0
Static network configuration gateway		192.168.0.2	192.168.0.2	192.168.0.2

6 Connection of several charging points to a backend system via LAN / Ethernet (RJ45) and an external router

Requirements for the network:

- ✓ The charging stations must be on the same network.
- 📄 “4 Set up network” [▶ 17]
- ✓ The router in the network has an Internet connection.
- ✓ The IP address configuration can take place statically or dynamically.

Settings in the web interface of each networked charging station

- ▶ In the web interface of each networked charging station, navigate to the menu “Backend” > “Connection” or “OCPP”.

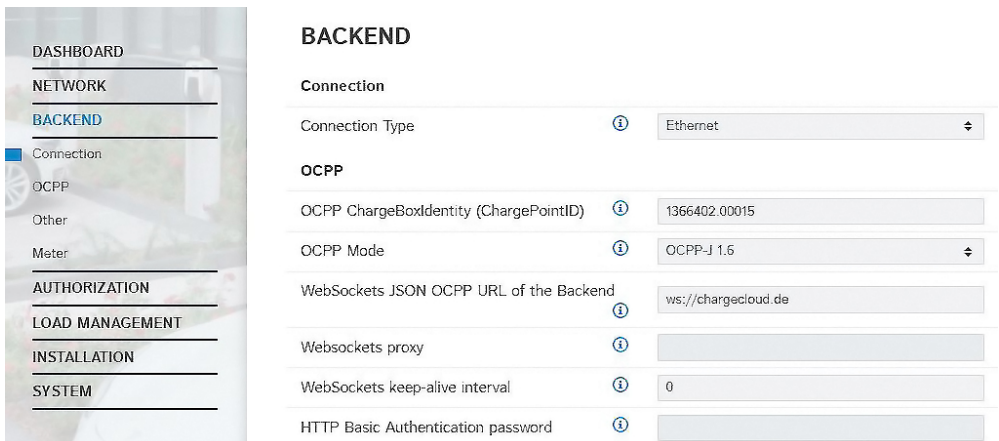

Fig. 22: Web interface for connecting several charging points to a backend system via LAN / Ethernet (RJ45) and an external router

- ▶ Set the following parameters in the web interface of each networked charging station:

Parameter	Web interface setting
Connection Type	▶ Select “Ethernet”.
OCPP Mode	▶ Select “OCPP-J 1.6”.
WebSockets JSON OCPP URL of the Backend	▶ Enter the WS / WSS-URL of the OCPP backend system.
HTTP Basic Authentication password	▶ Enter the password for the HTTP basic authentication. An empty field means that HTTP basic authentication is not used.



We recommend using a secure Internet connection to communicate with the backend system. This can be done, for example, via a SIM card provided by the backend system operator or via a connection secured by TLS. In the case of access via the public Internet, at least the HTTP basic authentication should be activated, otherwise the data will be transmitted in a format that is readable for unauthorised third parties.



Information concerning OCPP and the password for the HTTP basic authentication are provided by your backend system provider.

- ▶ Click the “Save” button to save the setting(s).

7 Operation of local and dynamic load management (DLM)

The main purpose of load management is to ensure that as many vehicles as possible can be charged simultaneously, without overloading the power supply. The available energy must be distributed to the connected vehicles as evenly as possible. In the process, the vehicles must be charged with the highest possible charging current.

Requirement(s):

✓ The charging stations must be on the same network.

📄 “4 Set up network” [▶ 17]

There are two principles concerning the supply of the entire charging infrastructure at the location:

- The value of the maximum upper current limit is static and corresponds, for example, to the value of the building connection or the back-up fuse of the charging infrastructure.
- The value of the maximum upper current limit is dynamic and regulated, for example, as a function of the other consumers at the location.

Benefits

- Cost reduction / cost avoidance
- Peak load avoidance
- Reduced expansion of the grid connection
- Energy consumption during favourable tariff periods
- Optimal use of renewable energy
- Flexibility and convenience
- Increase availability of charging points
- Intelligent, dynamic controls for fastest possible, cost-optimised charging

Operating principle

In load management, one of the charging points in the network always assumes the coordination function. This charging point, which is also referred to as the DLM-Master, distributes the maximum available energy proportionately to the remaining charging points in the network. Any charging point in the network can be configured as the DLM-Master in the web interface (regardless of whether it is already configured as a Gateway charging point). All other charging points must be configured as DLM-Satellites.

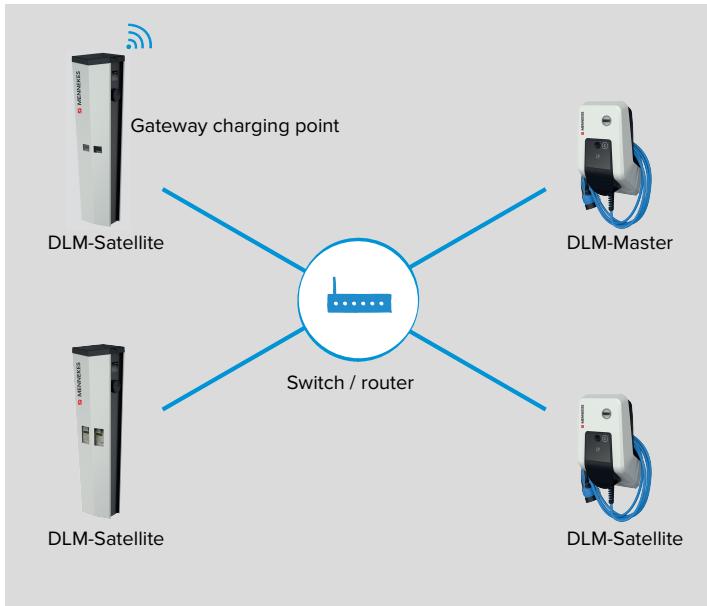

Fig. 23: DLM-Master – DLM-Satellites

- Load management distributes the maximum available power to the connected vehicles.
- Load management responds as a function of all internal phase-accurate measurements.
- All current charging currents are considered in “real time”.
- Load management regulates the connected vehicles in the entire charging point network on an equal basis. Regulation takes place in 1 A steps.
- If the charging current on the vehicle side is reduced at the end of the charging process or to pause the charge, the released power reserve is distributed to the other connected vehicles.
- If an external energy meter is connected to the DLM-Master, the maximum available power depends on the remaining power consumption at the location and is automatically reduced or increased according to the load. If an external energy meter is connected, therefore, additional power consumers (outside the charging infrastructure) can be considered.

View networked charging stations

Once a DLM-Master has been defined in the web interface, the menu “Dashboard” > “DLM Status” is displayed. No settings can be made here. Information is provided about the network connection of the respective charging station. In the web interface of the DLM-Master, additional information about the network settings (“DLM Configuration”) and the status of the networked charging stations (“DLM Connected Slaves”) is provided.

The various options (use cases) for load management and the necessary configurations are described below.

7.1 Use case: Car park with two charging points

Load management is not configured in the delivery state, hence this use case must be considered here.

Application field:

For cost reasons, it may be appropriate during the installation not to lay the supply line for the full capacity of the charging station (e.g. for AMEDIO® 64 A (2×22 kW)), but limit it to 32 A, for example. Load management allows a connected vehicle to charge with 32 A. As soon as another vehicle is connected, the charging power is limited to 16 A per charging point. This means that the fuse F3 does not trip.

Objective of load management:

The total charging current of both charging points must not exceed the rated current of fuse F3, so that the power supply and the operational reliability of the charging station are always ensured.

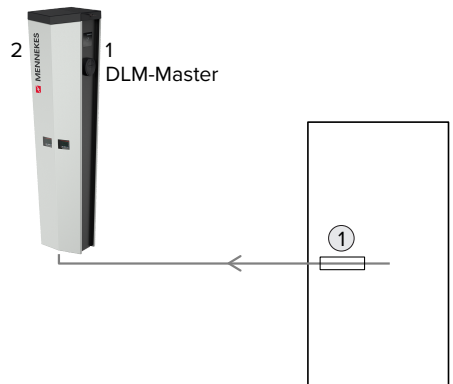

Fig. 24: Load management for a car park with two charging points

1 Circuit breaker for CP1 and CP2 / EVSE Sub-Distribution Limit

In the web interface of the DLM-Master in the parameters "EVSE Sub-Distribution Limit (L1/L2/L3) [A]" and "Operator EVSE Sub-Distribution Limit (L1/L2/L3) [A]", the maximum connection current of the charging station must be configured with 32 A for all three phases.

Settings in the web interface of each networked charging station

- In the web interface of each networked charging station, navigate to the menu "Load Management" > "Dynamic Load Management".

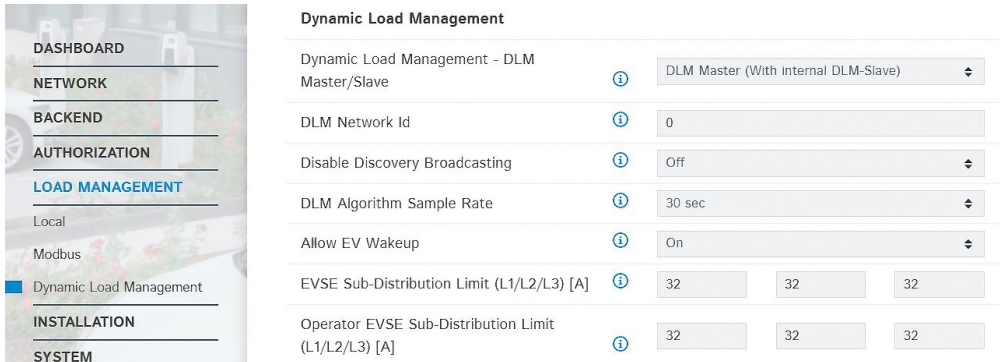

Fig. 25: Web interface of the DLM-Master for configuring load management

► Set the following parameters in the web interface of each networked charging station:

Parameter	Web interface setting
Dynamic Load Management - DLM Master/ Slave	Used to set the charging point function for load management in a DLM network. The charging point that is assigned the setting “DLM Master (With internal DLM-Slave)”, is the DLM-Master. The charging point that is assigned the setting “DLM Slave (Master-Auto-Discovery)”, is the DLM-Satellite.
DLM Network Id	The charging points must be assigned to the same DLM network.
EVSE Sub-Distribution Limit (L1/L2/L3) [A]	Maximum mains current available for load management. This parameter can be set only in the web interface of the DLM-Master.
Operator EVSE Sub-Distribution Limit (L1/L2/L3) [A]	Upper current limit for load management. This value is smaller than or equals the value for “EVSE Sub-Distribution Limit (L1/L2/L3) [A]”. This parameter can be set only in the web interface of the DLM-Master.

► Click the “Save” button to save the setting(s).

✓ Load management now ensures that the outer conductor currents in the supply line are limited to the respective current value.

Example

Parameter	Web interface setting					
	CP1 / DLM-Master			CP2 / DLM-Satellite		
Dynamic Load Management - DLM Master/Slave	DLM Master (With internal DLM-Slave)			DLM Slave (Master-Auto-Discovery)		
DLM Network Id	0			0		
EVSE Sub-Distribution Limit (L1/L2/L3) [A]	32	32	32	-	-	-
Operator EVSE Sub-Distribution Limit (L1/L2/L3) [A]	32	32	32	-	-	-

If necessary, a load profile for 24 hours can be set up.

 “7.7 Static load profile for 24 hours” [53]

7.2 Use case: Car park with several charging points

Application field:

For cost reasons, it may be appropriate during the installation not to lay the supply line for the full capacity of the charging point network (all charging stations on one supply line), but to limit the capacity. All connected vehicles charge with full charging power until the maximum current for the supply line has been reached. If another vehicle is plugged into a charging point, load management distributes the charging currents intelligently to all vehicles.

Objective of load management:

The total charging current of all charging points must not exceed the rated current of fuse F3, so that the power supply and the operational reliability of the charging stations are always ensured.

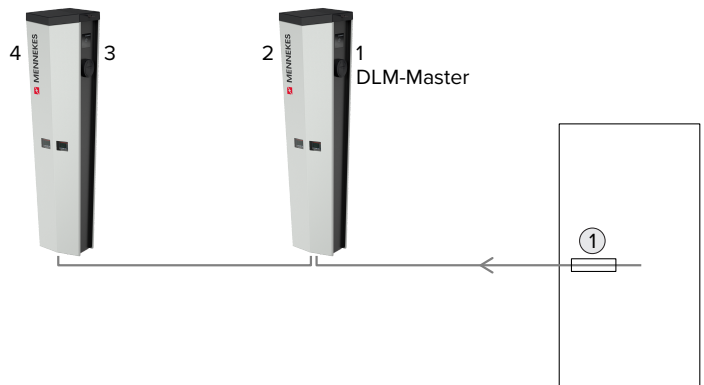

Fig. 26: Load management for a car park with multiple charging points (example)

1 Main fuse / EVSE Sub-Distribution Limit

Example

Parameter	Web interface setting					
	CP1 / DLM-Master			CP2 / CP3 / CP4 / DLM-Satellite		
Dynamic Load Management - DLM Master/Slave	DLM Master (With internal DLM-Slave)			DLM Slave (Master-Auto-Discovery)		
DLM Network Id	0			0		
EVSE Sub-Distribution Limit (L1/L2/L3) [A]	100	100	100	-	-	-

Parameter	Web interface setting					
	CP1 / DLM-Master			CP2 / CP3 / CP4 / DLM-Satellite		
Operator EVSE Sub-Distribution Limit (L1/L2/L3) [A]	100	100	100	-	-	-

If necessary, a load profile for 24 hours can be set up.

 "7.7 Static load profile for 24 hours" [▶ 53]

7.3 Use case: Car park with several charging stations and common power connection

Application fields:

- For cost reasons, it may be appropriate during the installation not to configure the supply line for the full capacity of all charging stations on each respective supply line, but to limit the capacity. All connected vehicles charge with full charging power until the maximum current for the supply line has been reached. If another vehicle is plugged into a charging point, load management distributes the charging currents intelligently to all vehicles.
- The charging points can be connected to different supply lines and still be in the same network (e.g. for common communication with a backend system). By assigning a load management network ID ("DLM Network Id"), load management can be operated separately for each supply line.

Objective of load management:

To ensure the power supply and operational reliability of a network of defined charging points.

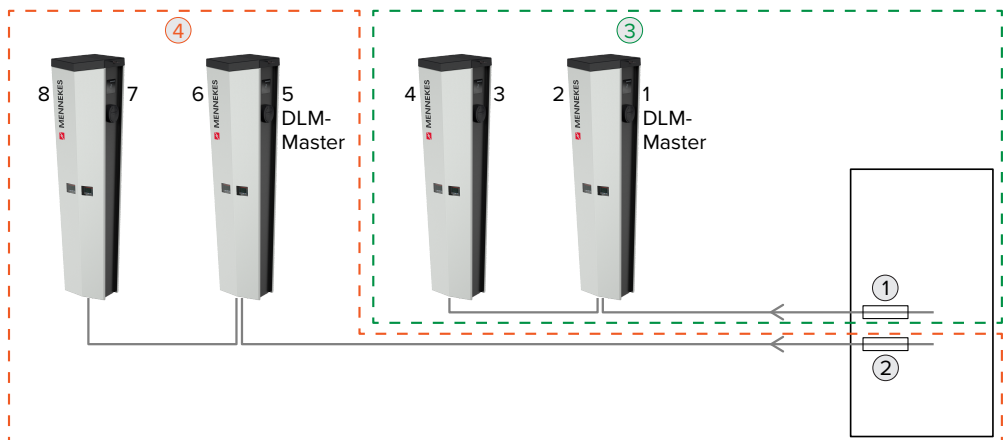

Fig. 27: Load management of a car park with multiple charging points and a common network connection (example)

- 1 Main fuse for charging point network with network ID =1 / EVSE Sub-Distribution Limit
- 2 Main fuse for charging point network with network ID =0 / EVSE Sub-Distribution Limit

- 3 Network ID = 1 (marked green)
- 4 Network ID = 0 (marked orange)

Settings in the web interface of each networked charging station

► In the web interface of each networked charging station, navigate to the menu “Load Management” > “Dynamic Load Management”.

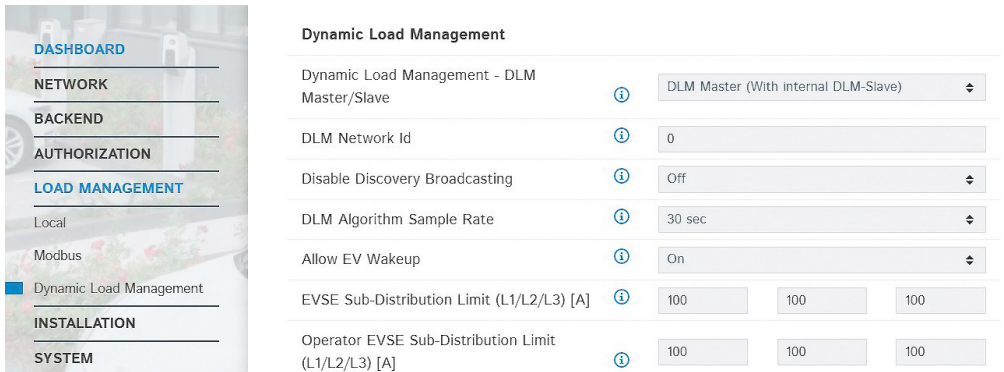

Fig. 28: Web interface of the DLM-Master for configuring load management

► Set the following parameters in the web interface of each networked charging station:

Parameter	Web interface setting
Dynamic Load Management - DLM Master/ Slave	Used to set the charging point function for load management in a DLM network. The charging point that is assigned the setting “DLM Master (With internal DLM-Slave)”, is the DLM-Master. The charging point that is assigned the setting “DLM Slave (Master-Auto-Discovery)”, is the DLM-Satellite.
DLM Network Id	The charging points must be assigned to the same DLM network.
EVSE Sub-Distribution Limit (L1/L2/L3) [A]	Maximum mains current available for load management. This parameter can be set only in the web interface of the DLM-Master.
Operator EVSE Sub-Distribution Limit (L1/L2/L3) [A]	Upper current limit for load management. This value is smaller than or equals the value for “EVSE Sub-Distribution Limit (L1/L2/L3) [A]”. This parameter can be set only in the web interface of the DLM-Master.

- Click the “Save” button to save the setting(s).
- ✓ Load management now ensures that the outer conductor currents in the supply line are limited to the respective current value.

Example

Settings in the web interface – DLM Network Id: 0						
Parameter	CP5 / DLM-Master			CP6 / CP7 / CP8 / DLM-Satellite		
Dynamic Load Management - DLM Master/Slave	DLM Master (With internal DLM-Slave)			DLM Slave (Master-Auto-Discovery)		
DLM Network Id	0			0		
EVSE Sub-Distribution Limit (L1/L2/L3) [A]	100	100	100	-	-	-
Operator EVSE Sub-Distribution Limit (L1/L2/L3) [A]	100	100	100	-	-	-

Settings in the web interface – DLM Network Id: 1						
Parameter	CP1 / DLM-Master			CP2 / CP3 / CP4 / DLM-Satellite		
Dynamic Load Management - DLM Master/Slave	DLM Master (With internal DLM-Slave)			DLM Slave (Master-Auto-Discovery)		
DLM Network Id	1			1		
EVSE Sub-Distribution Limit (L1/L2/L3) [A]	100	100	100	-	-	-
Operator EVSE Sub-Distribution Limit (L1/L2/L3) [A]	100	100	100	-	-	-

If necessary, a load profile for 24 hours can be set up.

 “7.7 Static load profile for 24 hours” [\[53 \]](#)

7.4 Use case: Consideration of dynamic measured values of an external energy meter (Standalone application with one charging point and Master-Satellite application with several charging stations and common power connection)

Requirement(s):

- ✓ The load management system cannot distribute the power supply dynamically to the individual charging points. Therefore, the connection lines of the charging stations must be designed for the full capacity of all connected charging stations. Alternatively, a maximum charging current can be assigned to the charging points. To do this, the parameter “ Installation Current Limit [A]” must be set so that the sum of all charging currents in a DLM network does not exceed the capacity of the connecting cables.
- ✓ All charging stations must have been assigned the same DLM Network Id.
- ✓ A network-compatible Modbus energy meter with Ethernet interface and TCP/IP protocol (e.g. Siemens PAC 2200) must be installed in the power distribution and integrated via the switch into the same network as the charging stations.

Objective of load management:

To ensure the power supply and operational reliability of a network of charging points.

Application field:

To prevent an overload at the building connection with one or more charging points (blackout protection), it is necessary to record the current values from the building connection with an additional external energy meter. The energy meter also takes account of other consumers in the building.

The external energy meter can be placed in such a way that only the external consumers are measured or that the external consumers and the charging station(s) are measured.

The ECU is compatible with the following energy meters:

1. Siemens PAC2200:

- Indirect measurement via a transducer (5 A):
 - 7KM2200-2EA30-1JA1 (with MID approval)
 - 7KM2200-2EA30-1EA1 (without MID approval)
- Direct measurement (up to 65 A)
 - 7KM2200-2EA40-1JA1 (with MID approval)
 - 7KM2200-2EA40-1EA1 (without MID approval)

2. Phoenix EEM-MB371-EIP 2907976:

This energy meter also allows the direct connection of Rogowski coils. The energy meter must be configured as a Modbus TCP slave.

3. Kostal Smart Energy Meter 10507524:

This requires the setting "Modbus B-Control EM300-LR (TCP)" in the web interface (parameter "Meter configuration (Second)"). The energy meter also must be configured as a Modbus TCP slave.

4. TQ Energy Manager EM 420-LLRR:

This requires the setting "Modbus B-Control EM300-LR (TCP)" in the web interface (parameter "Meter configuration (Second)"). The energy meter also must be configured as a Modbus TCP slave.

7.4.1 Option 1: Energy meter measures external consumers only

The DLM-Master queries at regular intervals the current consumption measured by the energy meter M2. The DLM-Master subtracts the current consumption at energy meter M2 from the set value in the parameter "Main Distribution Limit (L1/L2/L3) [A]" and makes the remaining power available to the charging stations. The charging current is distributed evenly to all connected vehicles.

Networking between the energy meter and the charging station takes place via a direct connection or via a switch / router.

Connection example: Single-family house (standalone)

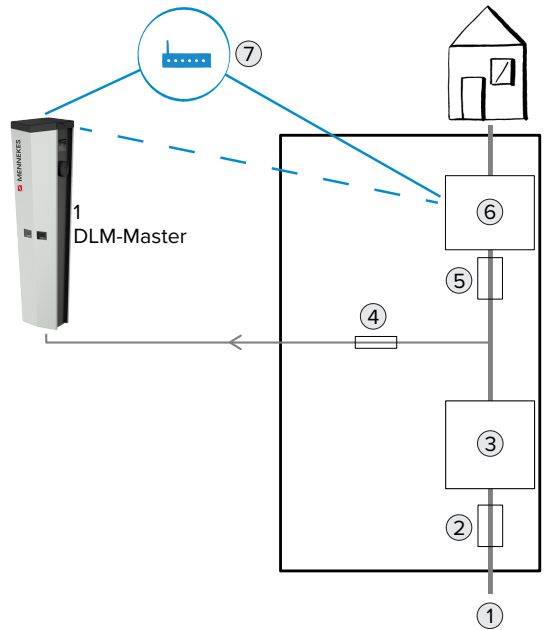

Fig. 29: Energy meter measures external consumer only: Connection example for a single-family dwelling (standalone)

- 1 Electrical network
- 2 Main fuse F1 / EVSE Sub-Distribution Limit
- 3 Main energy meter M1
- 4 Circuit breaker for CP1
- 5 Fuse F2
- 6 Energy meter M2
- 7 Switch / router

Connection example: Apartment building (Master-Satellite)

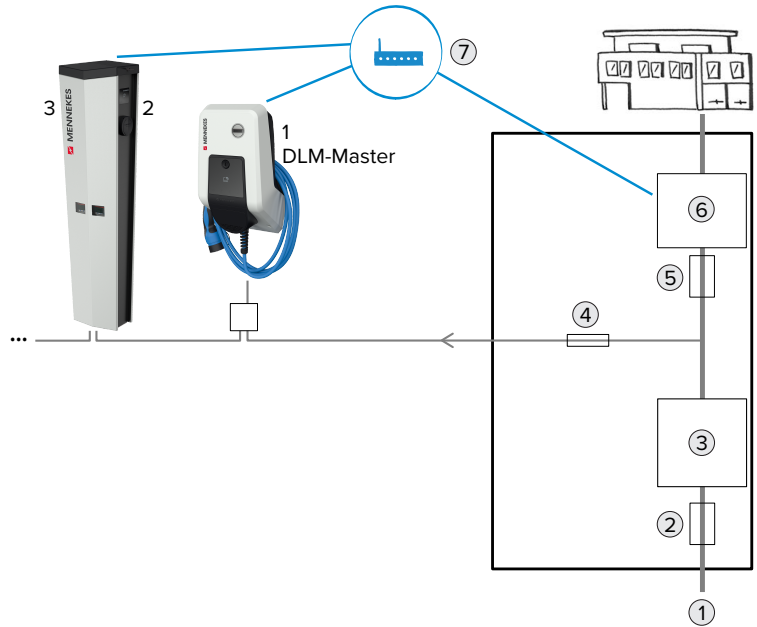
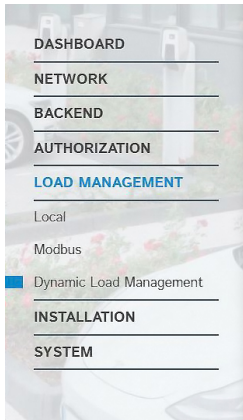

Fig. 30: Energy meter measures external consumers only: Connection example for an apartment building (Master-Satellite) (Example: AMTRON® with integrated residual current device and circuit breaker)

- 1 Electrical network
- 2 Main fuse F1 / EVSE Sub-Distribution Limit
- 3 Main energy meter M1
- 4 Circuit breaker for CP1, CP2, CP3, ...
- 5 Fuse F2
- 6 Energy meter M2
- 7 Switch / router

Settings in the web interface of the DLM-Master

- In the web interface of the DLM-Master, navigate to the menu “Load Management” > “Dynamic Load Management”.



Dynamic Load Management















Dynamic Load Management - DLM Master/Slave		DLM Master (With internal DLM-Slave) ▾		
DLM Network Id		0		
Disable Discovery Broadcasting		Off ▾		
DLM Algorithm Sample Rate		30 sec ▾		
Allow EV Wakeup		On ▾		
EVSE Sub-Distribution Limit (L1/L2/L3) [A]		100	100	100
Operator EVSE Sub-Distribution Limit (L1/L2/L3) [A]		100	100	100
External Meter Support		On ▾		
Meter configuration (Second)		Modbus Siemens 7KM2200 (TCP) ▾		
IP address of second meter		192.168.0.2		
Port number of Second Meter		80		
Main Distribution Limit (L1/L2/L3) [A]		100	100	100
External Load Headroom (L1/L2/L3) [A]		0	0	0
External Load Fallback (L1/L2/L3) [A]		9999	9999	9999
External Meter Location		Excluding EVSE Sub-Distribution ▾		

Fig. 31: Web interface of the DLM-Master for configuring load management

► Set the following parameters in the web interface of the DLM-Master:

Parameter	Setting
External Meter Location	► Select “Excluding EVSE Sub-Distribution”.

Example

Parameter	Setting: CP1 / DLM-Master		
Dynamic Load Management - DLM Master/Slave	DLM Master (With internal DLM-Slave)		
EVSE Sub-Distribution Limit (L1/L2/L3) [A]	100	100	100
Operator EVSE Sub-Distribution Limit (L1/L2/L3) [A]	100	100	100
External Meter Support	On		
Meter configuration (Second)	Modbus Siemens 7KM2200 (TCP)		
IP address of second meter	192.168.0.2		
Port number of Second Meter	80		
Main Distribution Limit (L1/L2/L3) [A]	100	100	100

Parameter	Setting: CP1 / DLM-Master
External Meter Location	Excluding EVSE Sub-Distribution

Query the IP address and port number of the Siemens 7KM2200 (TCP) energy meter

The F1, F2, F3 and F4 keys on the energy meter are required for this.

- ▶ Press the F4 key to open the menu.
- ▶ Press the F2 key and navigate to "Settings".
- ▶ Press the F4 key to open "Settings".
- ▶ Press the F3 key several times and navigate to "Communication".
- ▶ Press the F4 key to open "Communication".
- ▶ Press the F4 key to open "Modbus TCP".
- ▶ Press the F3 key and navigate to "IP: IP address of the meter". Make a note of the IP address of the energy meter.
- ▶ Press the F3 key several times and navigate to "Modbus Port". Make a note of the port number of the energy meter.
- ▶ Press the F1 key 4 times to close the menu.

7.4.2 Option 2: Energy meter measures external consumers and charging stations (total consumption)

The DLM-Master queries at regular intervals the current consumption measured by the energy meter M2. The DLM-Master regulates the individual charging currents of the charging points so that the measured value of the energy meter M2 does not exceed the set value "Main Distribution Limit (L1/L2/L3) [A]". The charging current is distributed evenly to all connected vehicles.

Networking between the energy meter and the charging station takes place via a direct connection or via a switch / router.

Connection example: Single-family house (standalone)

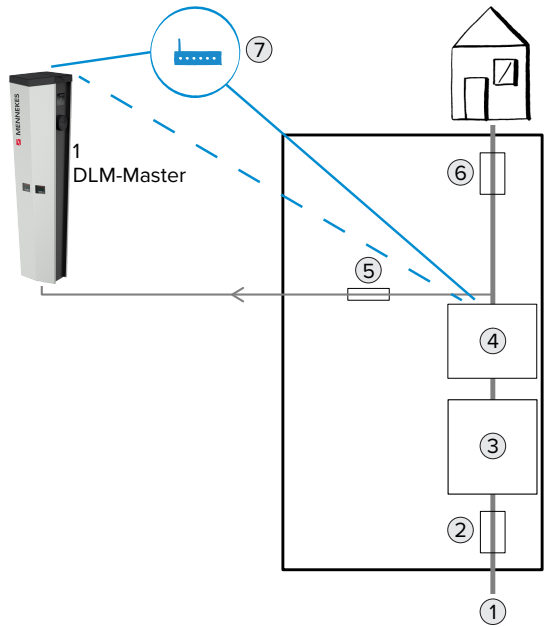

Fig. 32: Energy meter measures total consumption: Connection example for a single-family dwelling (standalone)

- 1 Electrical network
- 2 Main fuse F1 / EVSE Sub-Distribution Limit
- 3 Main energy meter M1
- 4 Energy meter M2
- 5 Circuit breaker for CP1
- 6 Fuse F2
- 7 Switch / router

Connection example: Apartment building (Master-Satellite)

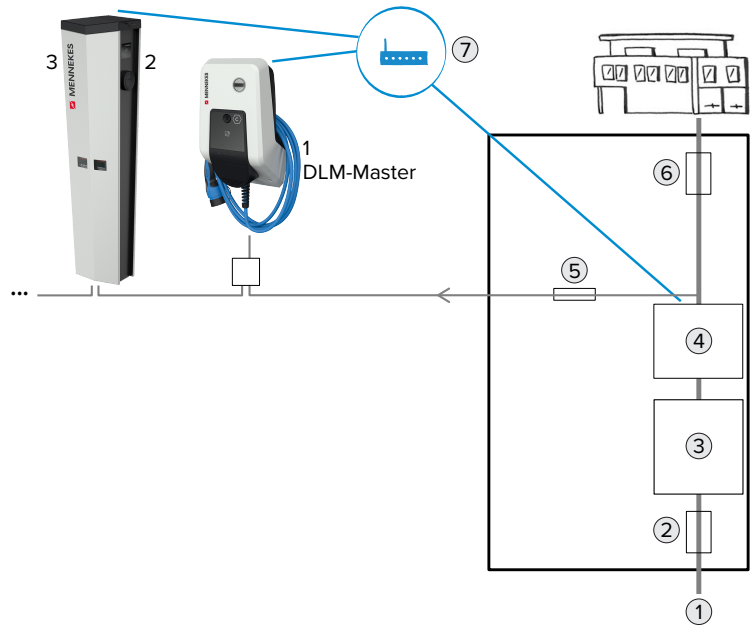
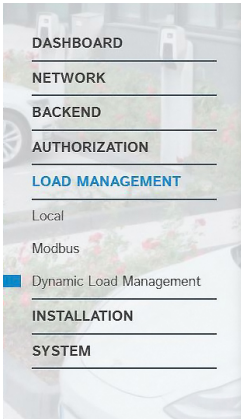

Fig. 33: Energy meter measures total consumption: Connection example for an apartment building (Master-Satellite) (Example: AMTRON® with integrated residual current device and circuit breaker)

- 1 Electrical network
- 2 Main fuse F1 / EVSE Sub-Distribution Limit
- 3 Main energy meter M1
- 4 Energy meter M2
- 5 Circuit breaker for CP1, CP2, CP3. ...
- 6 Fuse F2
- 7 Switch / router

Settings in the web interface of the DLM-Master

- In the web interface of the DLM-Master, navigate to the menu “Load Management” > “Dynamic Load Management”.



Dynamic Load Management















Dynamic Load Management - DLM Master/Slave		DLM Master (With internal DLM-Slave) ▾		
DLM Network Id		0		
Disable Discovery Broadcasting		Off ▾		
DLM Algorithm Sample Rate		30 sec ▾		
Allow EV Wakeup		On ▾		
EVSE Sub-Distribution Limit (L1/L2/L3) [A]		100	100	100
Operator EVSE Sub-Distribution Limit (L1/L2/L3) [A]		100	100	100
External Meter Support		On ▾		
Meter configuration (Second)		Modbus Siemens 7KM2200 (TCP) ▾		
IP address of second meter		192.168.0.2		
Port number of Second Meter		80		
Main Distribution Limit (L1/L2/L3) [A]		100	100	100
External Load Headroom (L1/L2/L3) [A]		0	0	0
External Load Fallback (L1/L2/L3) [A]		9999	9999	9999
External Meter Location		Including EVSE Sub-Distribution ▾		

Fig. 34: Web interface of the DLM-Master for configuring load management

► Set the following parameters in the web interface of the DLM-Master:

Parameter	Setting
External Meter Location	► Select “Including EVSE Sub-Distribution”.

Example

Parameter	Setting: CP1 / DLM-Master		
Dynamic Load Management - DLM Master/Slave	DLM Master (With internal DLM-Slave)		
EVSE Sub-Distribution Limit (L1/L2/L3) [A]	100	100	100
Operator EVSE Sub-Distribution Limit (L1/L2/L3) [A]	100	100	100
External Meter Support	On		
Meter configuration (Second)	Modbus Siemens 7KM2200 (TCP)		
IP address of second meter	192.168.0.2		
Port number of Second Meter	80		
Main Distribution Limit (L1/L2/L3) [A]	100	100	100

Parameter	Setting: CP1 / DLM-Master
External Meter Location	Including EVSE Sub-Distribution

Query the IP address and port number of the Siemens 7KM2200 (TCP) energy meter

The F1, F2, F3 and F4 keys on the energy meter are required for this.

- ▶ Press the F4 key to open the menu.
- ▶ Press the F2 key and navigate to “Settings”.
- ▶ Press the F4 key to open “Settings”.
- ▶ Press the F3 key several times and navigate to “Communication”.
- ▶ Press the F4 key to open “Communication”.
- ▶ Press the F4 key to open “Modbus TCP”.
- ▶ Press the F3 key and navigate to “IP: IP address of the meter”. Make a note of the IP address of the energy meter.
- ▶ Press the F3 key several times and navigate to “Modbus Port”. Make a note of the port number of the energy meter.
- ▶ Press the F1 key 4 times to close the menu.

7.5 Use case: Activate the interface (Modbus TCP server) for energy management systems (EMS)

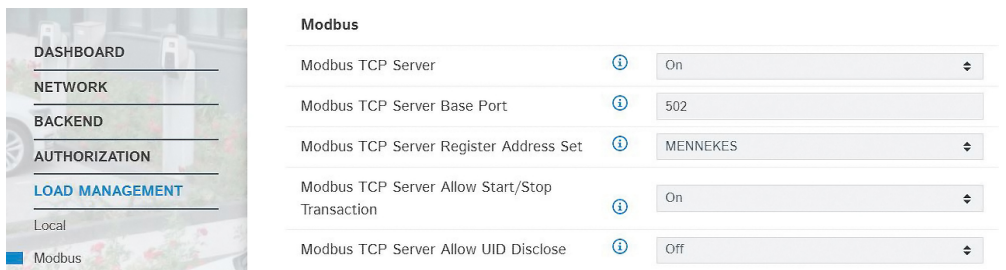

Fig. 35: Web interface for configuring the Modbus TCP

If each charging station is to be controlled separately by an EMS, the interface must be activated in the web interface of each charging station.

If the entire charging point network is to be controlled by an EMS, the interface only needs to be activated in the web interface of the DLM Master.

- ▶ Navigate to the menu “Load Management” > “Modbus” and set the following parameters:

Parameter	Setting
Modbus TCP Server	▶ Select “On”.
Modbus TCP Server Base Port	TCP port number on which the Modbus TCP socket accepts connections.
Modbus TCP Server Register Address Set	▶ Select “MENNEKES”.
Modbus TCP Server Allow Start/Stop Transaction	▶ Select “On”.

Parameter	Setting
Modbus TCP Server Allow UID Disclose	Setting to determine whether the energy management system is allowed to read out the UID of the RFID card of the current charging process.

The Modbus TCP register table can be made available on request.

7.6 Use case: Downgrade when using the energy meter Siemens 7KM2200 (TCP)

Requirement(s):

- ✓ The external energy meter Siemens 7KM2200 (TCP) was integrated in the network and configured.
- 📄 “7.4 Use case: Consideration of dynamic measured values of an external energy meter (Standalone application with one charging point and Master-Satellite application with several charging stations and common power connection)” [▶ 42]

The digital input of the energy meter can be used as a downgrade input to reduce the current for a single charging point or a charging point network. There are two options for controlling the digital input:

- via an external 12 V DC or 24 V DC control signal
- via a coupling relay and an additional power supply

Control via an external 12 V DC or 24 V DC control signal

The control signal can be generated, for example, by an external load shedding relay or an external timer. As soon as the 12 V DC or 24 V DC control signal is applied to the digital input, the charging current is reduced according to the set configuration.

- ▶ Connect the external control system to terminal 12 of the digital input.

Control via a coupling relay and additional power supply

The digital input can be controlled with a coupling relay (S0) and an additional power supply (1).

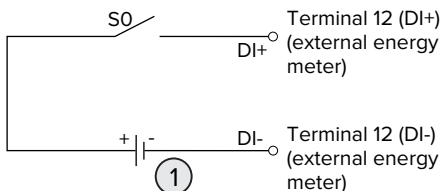

Fig. 36: Control via a coupling relay and additional power supply

- 1 External power supply, max. 30 V DC

- ▶ Connect the external control system to terminal 12 of the digital input.

Configuration in the web interface of the ECU

- ▶ Navigate to the menu “Load Management” > “Dynamic Load Management” and set the following parameters:

Parameter	Setting
Meter Digital Input Config	▶ Select “On”.
Meter Digital Input Current Offset (L1/L2/L3) [A]	The value by which the upper current limit for load management (parameter “Operator EVSE Sub-Distribution Limit (L1/L2/L3) [A]”) is reduced as soon as the digital input is energised.

- ▶ Click the “Save” button to save the setting(s).

The value by which the upper current limit is reduced as soon as the digital input is energised can be checked in the menu “Dashboard” > “DLM Status” under “Operator EVSE Sub-Distribution Limit (L1/L2/L3) [A]”.

Configuration of the digital input on the Siemens 7KM2200 energy meter (TCP)

The F1, F2, F3 and F4 keys on the energy meter are needed to select the required “On/Off-Peak” setting.

- ▶ Press the F4 key to open the menu.
- ▶ Press the F2 key and navigate to “Settings”.
- ▶ Press the F4 key to open “Settings”.
- ▶ Press the F3 key several times and navigate to “Integrated I/O”.
- ▶ Press the F4 key to open “Integrated I/O”.
- ▶ Press the F3 key and navigate to “Dig input”.
- ▶ Press the F4 key to open “Dig input”.
- ▶ Press the F4 key to open “Action”.
- ▶ Press the F3 key and navigate to “On/Off-Peak”.
- ▶ Press the F4 key to confirm “On/Off-Peak”.
- ▶ Press the F1 key 4 times to close the menu.

7.7 Static load profile for 24 hours

It is possible to store a load profile for 24 hours, for example, in order to bypass known, everyday bottlenecks in the power supply. The configured current limit values are not exceeded by the DLM.

Requirement(s):

- ✓ The product is connected to a backend system (for time synchronisation).

Settings in the web interface of the DLM-Master

- ▶ In the web interface, navigate to the menu “Load Management” > “Dynamic Load Management”.
- ▶ Set the following parameters in the web interface:

Parameter	Web interface setting
Dynamic Load Management - DLM Master/Slave	▶ Select “DLM Master (With internal DLM-Slave)”.
Maximum Current Scheduler	▶ Select “On”.

▶ Enter desired load profile.

Hour	L1	L2	L3	
0	32	32	32	Delete
7	16	16	16	Delete
16	6	6	6	Delete
20	32	32	32	Delete

Add Entry

Fig. 37: Entering the load profile

The settings in the above example lead to the following load profile:

Time (UTC)	Max. charging current [A]		
	L1	L2	L3
0 – 7 hrs	32	32	32
7 – 16 hrs	16	16	16
16 – 20 hrs	6	6	6
20 – 0 hrs	32	32	32

▶ Click the “Save” button to save the setting(s).



The listed times refer to universal time (UTC). In countries in other time zones (e.g. UTC+1), the times must be adjusted accordingly. If necessary, the times must also be adjusted according to summer and winter time.

8 Unbalanced load prevention

Unbalanced load refers to the uneven loading of the outer conductors of a three-phase alternating current network. To avoid unbalanced load, the load must be distributed evenly to the three outer conductors. In Germany, according to the technical connection conditions (TAB), the grid operator is limited to an asymmetry of up to 20 A at the grid connection point. An unbalanced load of the charging station can be prevented via the web interface.

An unbalanced load can be prevented in the following situations:

- Two charging points in one charging station (e.g. AMEDIO® Professional+ ; operating mode "Standalone Autostart"):
 - With two charging points in a network, the setting always refers to the combination of the two charging points. Here, too, this ensures that an unbalanced load never occurs on the supply line to the charging station.
 - With two charging points and one external energy meter in a network, an unbalanced load is prevented at the point of the external energy meter. In this way, other consumers are also considered.
- Several charging points (e. g. several AMEDIO® Professional+; operating mode "networked"):
 - With several charging points in a network, the setting always refers to the combination of all charging points. Here, too, this ensures that an unbalanced load never occurs on the supply line to the charging stations.
 - With several charging points and one external energy meter in a network, an unbalanced load is prevented at the point of the external energy meter. In this way, other consumers are also considered.

Settings in the web interface of each networked charging station

- ▶ In the web interface of each networked charging station, navigate to the menu "Load Management" > "Dynamic Load Management".

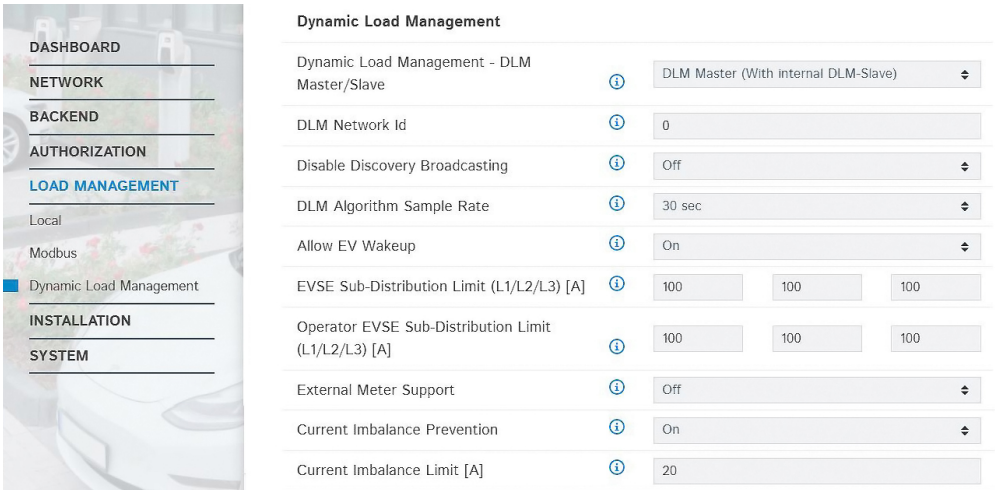

Fig. 38: Web interface of the DLM-Master for configuring the prevention of an unbalanced load

► Set the following parameters in the web interface of each networked charging station:

Parameter	Web interface setting
Dynamic Load Management - DLM Master/ Slave	Used to set the charging point function for load management in a DLM network. The charging point that is assigned the setting “DLM Master (With internal DLM-Slave)”, is the DLM-Master. The charging point that is assigned the setting “DLM Slave (Master-Auto-Discovery)” is the DLM-Satellite.
Current Imbalance Prevention	This setting specifies whether current imbalances should be limited. The individual phase currents are limited so that the value difference between the individual phase currents does not exceed the value in the parameter “Current Imbalance Limit [A]”. This parameter must be set for the DLM-Master only.
Current Imbalance Limit [A]	Maximum value difference between individual phase currents (in A). This parameter must be set for the DLM-Master only.

Example

Parameter	Web interface setting	
	CP1 / DLM-Master	CP2 / DLM-Satellite
Dynamic Load Management - DLM Master/Slave	DLM Master (With internal DLM-Slave)	DLM Slave (Master-Auto-Discovery)
Current Imbalance Prevention	On	-
Current Imbalance Limit [A]	20	-

9 Downgrade input

Only valid for the product variants with a switching input for downgrade (Professional+* 22, Professional+* PnC 22, Professional* 22, Professional* PnC 22).

By using the downgrade input, it is possible to reduce the grid connection charging current that is not available at its maximum level under certain circumstances or at certain times. For example, the downgrade input can be controlled by the following criteria or control systems:

- Electricity rate
- Clock position
- Load shedding
- Manual control
- External load management

The charging current can either be reduced for load management of the entire charging point network or for each individual charging point.

To reduce the charging current for the load management of the entire charging point network, an external 230 V control signal is required, which is applied to the DLM-Master. To reduce the charging current for each individual charging point, an external 230 V control signal is required for each charging point. The control signal can be generated, for example, by an external load shedding relay or an external time switch. As soon as the 230 V control signal is applied to the downgrade input, the charging current is reduced according to the set configuration in the web interface.

Installation

ATTENTION

Material damage due to improper installation

Improper installation can damage the product or lead to malfunctions. Observe the following requirements during the installation:

- ▶ The control signal voltage must not exceed 230 V.
- ▶ Select suitable cable routing to avoid interference.
- ▶ Provide for secure separation of the remaining installation from the highest occurring voltage.

 Observe the circuit diagram.

Requirement(s):

- ✓ The control system is installed externally.
-  Observe the operating and installation manual.

Configuring the downgrade input of the entire charging point network



It is not possible to reduce the charging current for the entire charging point network and for an individual charging point at the same time. The settings in the web interface cannot then be saved and an error message appears.

- In the web interface of the DLM-Master, navigate to “Load Management” > “Dynamic Load Management”.



Fig. 39: Web interface of the DLM-Master for configuring the downgrade input of the entire charging point network

- In the web interface, set the following parameters of the DLM-Master:

Parameter	Setting
Dynamic Load Management - DLM Master/Slave	► Select “DLM Master (With internal DLM-Slave)”.
External Input 1 Config (alternative: External Input 2 Config)	► Select “Enable Opto 2”.
Ext. Input 1 Current Offset (L1/L2/L3) [A] (alternative: Ext. Input 2 Current Offset (L1/L2/L3) [A])	Current value by which the charging current is reduced. The current values must be entered as negative values (-).



The input "OPTO 1" is not assigned.

Configuring the downgrade input of an individual charging point



It is not possible to reduce the charging current for the entire charging point network and for an individual charging point at the same time. The settings in the web interface cannot then be saved and an error message appears.

- In the web interface, navigate to “Load Management” > “Local”.

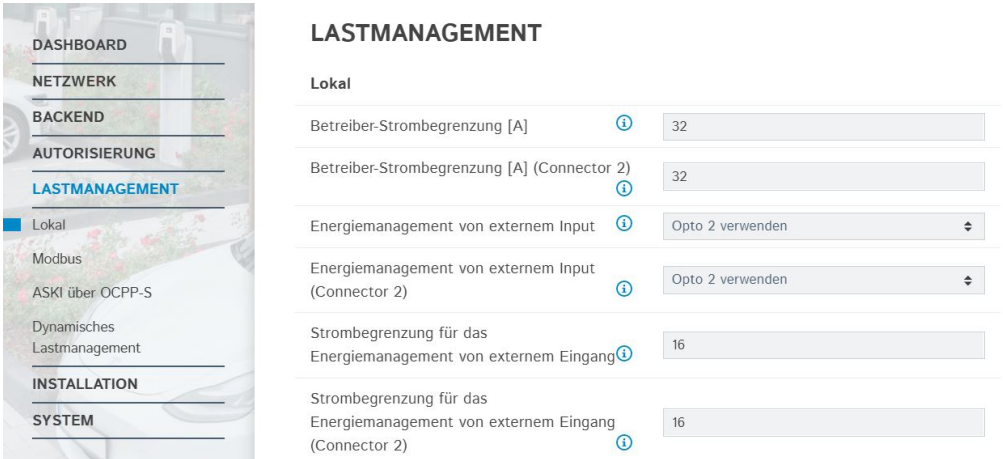

Fig. 40: Web interface for configuring the downgrade input of an individual charging point

► Set the following parameters in the web interface:

Left-hand charging point	
Parameter	Setting
Energy management from external input	► Select "Enable Opto 2".
Current limit for energy management from external input	Current value to which the charging current is reduced.
Right-hand charging point	
Parameter	Setting
Energy management from external input (Connector 2)	► Select "Enable Opto 2".
Current limit for energy management from external input (Connector 2)	Current value to which the charging current is reduced.

i The input "OPTO 1" is not assigned.

10 Glossary

Term	Explanation
DLM network / DLM-Master / DLM-Satellite or DLM-Slave (designation in the web interface)	<p>Dynamic Load Management</p> <p>Load management reduces the charging currents of all charging points in a DLM network as soon as the sum of all charging currents exceeds the adjustable current limit for load management. Load management can operate in a DLM network or at stand-alone charging points.</p>
ECU	<p>Electronic Control Unit</p> <p>control unit</p>
EMS	<p>Energy Management System</p>
Gateway charging point	<p>The Gateway charging point acts in the network as a portal through which the entire network is connected to a backend system. The Gateway charging point can be any master charging point that has a wireless communication modem and a SIM card for wireless communication.</p>
CP	<p>Charging point</p>
CS	<p>Charging station</p>
Master / Slave	<p>Both charging points in the AMEDIO® product are pre-configured as a master/slave connection (for OCPP). Both charging points can be configured via the Slave-ECU.</p> <ul style="list-style-type: none"> ■ Master-ECU = ECU on the left-hand side = AF1 ■ Slave-ECU = ECU on the right-hand side = AF2
Network	<p>An Ethernet network (referred to here as “network”) consists of a number of charging stations that are networked via Ethernet. Local networking can be used for the following functions:</p> <ul style="list-style-type: none"> ■ Operation of load management ■ Connection of several charging points to a backend system via a SIM card (wireless communication) <p>It is possible to build a DLM network and a network for connection to a backend system together in a network.</p>

MENNEKES

Elektrotechnik GmbH & Co. KG

Aloys-Mennekes-Str. 1
57399 KIRCHHUNDEM
GERMANY

Phone: +49 2723 41-1
info@MENNEKES.de

www.chargeupyourday.com

